

RAPTOR and HAWC Robotic Vehicles

RAPTOR is an extreme-terrain-capable Uncrewed Ground Vehicle (UGV), engineered to withstand harsh environments. RAPTOR is a durable, reliable platform, ideally suited to industrial and military applications, capable of transporting large, heavy payloads over challenging terrain.

A patented, highly efficient electric drive system provides exceptional torque to the wheels and is configured with fail-safe brakes and a quick-access neutral gear, enabling high-speed towing operations. The entire mechanical drivetrain is contained within sealed, oil-filled cavities for minimal service and long life.

RAPTOR's layout provides excellent ground clearance while maintaining a low centre-of-gravity for stability on slopes. On-board power is provided by internally housed high-capacity batteries, configured to meet desired mission requirements, and providing emissions-free, near-silent operations.

HAWC is an optionally-crewed version of RAPTOR, fitted with 2 crew seats and automotive-style secondary controls.



RAPTOR (above) and HAWC (below)



Sample customer configurations of RAPTOR and HAWC

Key Features

- 6x6 drive with patented skid-steer for extreme terrain mobility
- Robust, all-steel, welded chassis and lower body
- Low ground pressure, run-flat, tires
- Electric drive for emission-free, near-silent operation
- Local RF remote control operation (plus automotive controls for HAWC)
- Open-concept flat deck to accommodate payloads and sensor packages
- 1,000+ kg payload capacity (standard deck rated for 1,000 kg)
- Very low service interval (200 hrs or 4-years of operation)
- ITAR-free

Customers who want a capable and robust UGV choose RAPTOR.

Whether your mission is logistics resupply in contested AOs, remote C4ISR, cargo transport through hazardous terrain, mobile transport of offensive or defensive systems, or any other dull, dirty, or dangerous role, you need RAPTOR.

Options and Customization

- Extended battery capacity
- On-vehicle charger
- Integrated diesel generator (extended ops)
- Enhanced export power
- Autonomy kit (waypoint nav, follow, teach)
- High-capacity winch (forward or rear)
- Wheel and tire options (road, mud, sand, etc.)
- Bilge pumps
- Fully custom features on request

RAPTOR and HAWC Robotic Vehicles

Indicative technical details for a RAPTOR UGV with standard features:

Length	3.88 m
Wheelbase	2.04 m
Overall width	1.65 m
Track	1.30 m
Height (deck)	0.95 m
Height (cowl)	1.20 m
Drive	6x6 with skid steer
Driveline	Transaxle with chain drive
Motor	96 VDC electric drive/steer
Wheels	15" (standard)
Tires	35" (standard)
Curb weight	1350 kg (no options)
GVWR	2950 kg
Payload deck	1.4 m x 3.1 m (w/o generator)
Top speed	20-25 km/hr
Ground pressure	~30 kPa
Ground clearance	270 mm
Turning circle	0 m (pivot turn)
Approach angle	48 degrees
Departure angle	45 degrees
Fording	>1 m (no preparation)
Hill climb	60 % (hard surface)
Side slope	35 % (w/o payload)
Range	30+ km (standard battery)
Lights	Headlights, taillights
Transport	Front/rear lift/tow lugs
Tow	Rear hitch receiver (2") Tow up to 2000 kg Be towed at 80 km/hr+
Export power	5 kW @ 24V (NATO) 12 V, 5V USB

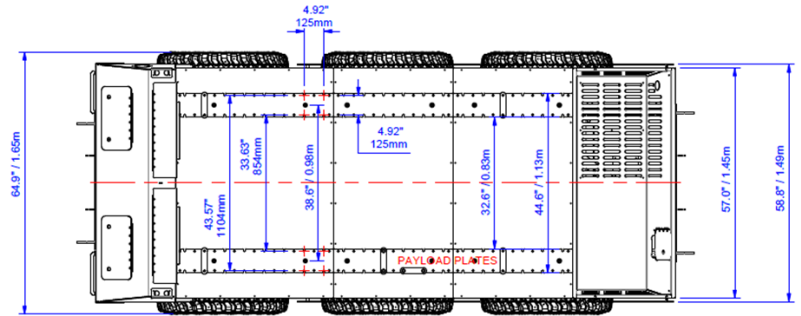

RAPTOR with Optional Generator

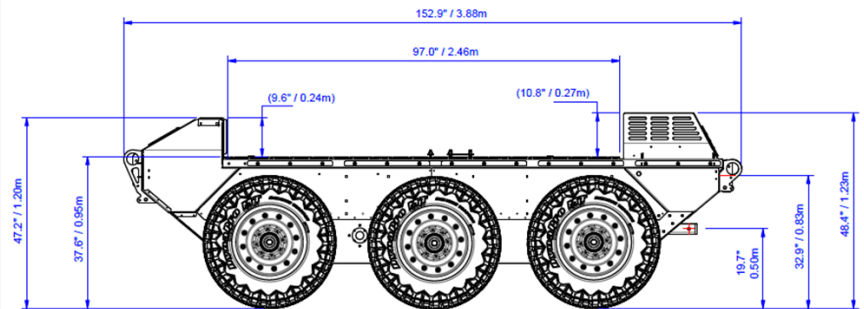

Canadensys Aerospace Corporation, headquartered in Toronto, Canada, is an innovative systems engineering company serving customers around the world.

We blend our advanced hardware capabilities with smart, rugged designs to develop unique solutions for harsh environments.

Our modern, commercial, business approach enables effective program and mission development for both commercial and government customers.

For more information, email: info@canadensys.com



Copyright 2025/01 Canadensys Aerospace Corporation. Canadensys reserves the right to make changes without further notice to any products herein. Canadensys makes no warranty, representation or guarantee regarding the suitability of its products for any particular purpose. Technical parameters for each application must be validated by the customer. Indicative performance information is for reference only. Actual performance may vary with application and specific integration arrangements. Please consult Canadensys for integration support.